

L5-CEC
L10-CEC
L10-DC-CEC
L14-CEC
L20-CEC
L25-CEC
L30-CEC

L5-DC-CEC
L10-NP-CEC
L10-DC-2H
L14-DC-CEC
L20-DC-CEC
L25-DC-CEC
L30-DC-CEC

**ABOVE MODELS ARE CLASS 2 OUTPUT
(15-55 VDC LED LOADS ONLY)**

L20-HVO L20-DC-HVO
L25-HVO L25-DC-HVO
L30-VHO L30-DC-HVO

HVO models are Class 1 OUTPUT (50-255 VDC LED LOADS ONLY)



Tel:877-774-4775



Standard Input Voltage is 120-277 Vac, 50/60 Hz

When model number is followed by – 480 , input voltage is 347– 480 VAC, 50/60 Hz.

READ AND FOLLOW ALL SAFETY INSTRUCTIONS

1. Do not join battery connector until installation is complete and AC power is supplied to the emergency driver.
2. This product is intended for use with an emergency LED lighting load and supplies nominal power and a maximum voltage in emergency mode for a minimum of 90 minutes (or 2 hours for the -2H models).
3. An unswitched AC power source is required (115-277 VAC, 50/60 Hz or —480 would need 347-480 Vac) to power these units.
4. This product's chassis must be grounded.
5. This product is suitable for use in damp locations where the ambient temperature is 0°C minimum, to +55°C maximum.
6. This product is also suitable for installation in sealed and gasketed fixture. This product is not suitable for heated air outlets and wet or hazardous locations. For the 5/10W models, maximum allowable case temp is 66°C. For the 14/20/25/30W models, maximum allowable case temp is 70°C. See page 5 of this document for TC measurement location.
6. This product contains a rechargeable LiFePO4 battery. The battery must be recycled or disposed of properly.
7. Make certain all connections are in accordance with the National Electrical Codes and any local regulations.
8. This emergency LED driver is suitable for both factory or field installation. For field installation, please see the instructions on page 3.
9. Do not install near gas or electric heaters.
10. The use of accessory equipment is not recommended by the manufacturer and may cause an unsafe condition.
11. Do not use this product for applications other than the intended use.
12. Equipment should be mounted in locations and at heights where it will not be subjected to tampering by unauthorized personnel.
13. This device complies with part 15 of the FCC Rules. Operation is suitable to the following two conditions: (1) This device may not cause harmful interference, and (2) This device must accept any interference that may cause undesired operation.
14. To reduce the risk of electric shock, disconnect both normal and emergency power source and disconnect the battery connector of the emergency driver before servicing.
15. Do not attempt to service the battery. This is a sealed unit. Replace entire unit when necessary. Contact the manufacturer for information on service.
16. Servicing should be performed by qualified service personnel only.

INSTALLATION



CAUTION: DO NOT JOIN BATTERY CONNECTOR UNTIL INSTALLATION IS COMPLETE AND AC POWER IS SUPPLIED TO THE EMERGENCY DRIVER.

NOTE: Make sure the necessary branch circuit wiring is available. An unswitched source of power is required. The emergency driver must be fed from the same branch circuit as the AC driver.

This product is suitable for field installation with suitable LED loads. There are Three (3) checks to determine if your luminaire is eligible for field installation.

1. Ensure the LED load's rated power is greater than or equal to the power output of this emergency LED driver. This is to ensure that this emergency product will not produce more power than the LED load can handle. Thus ensuring that the LED load will not be damaged when the system is in the emergency mode.
2. Verify that the forward voltage of the luminaire's LED array is within the limits of this emergency LED driver. The forward voltage of the LED array is commonly designated as V_f and should be found on the luminaire, in the luminaire specifications, or imprinted directly on the LED arrays. If multiple LED arrays are to be driven, verify that the total forward voltage is within the limits of this product. Using a voltage meter, it may be possible to directly measure the voltage across the LED arrays when operating from the AC driver.
3. Ensure the output current of the LED driver does not exceed 5.0 Amps. This is the current into the red and blue output wire.

NOTE: This product has been designed to reliably interface with a wide selection of LED loads and is electrically compatible with every simple LED array that meets criteria 1 and 2 above. However compatibility cannot be guaranteed with all current and future LED systems. Compatibility testing of the end-use systems is suggested . Please contact the factory with any questions.

NOTE: After installation, it will be necessary to measure the egress lighting illumination level to ensure it complies with national state and local code requirement.

Installation of this emergency LED driver will vary based on the luminaire type, however generally follow these steps.

STEP #1 INSTALLING THE EMERGENCY DRIVER

- ◆ Disconnect AC power from the LED luminaire.
- ◆ Mount the emergency LED driver by the mounting tabs using appropriate screws (not provided). The luminaire's installation instructions may provide guidance on the recommended mounting location.

NOTE: Considerations must be made to protect the wires on models that have no flexible conduit when installed outside of the luminaire.

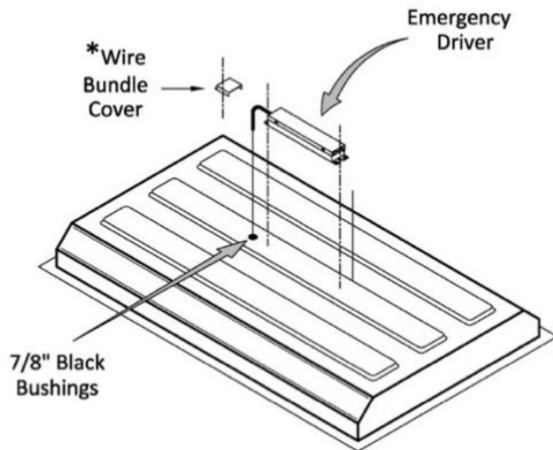

Note:

If the application requires the emergency LED driver to be mounted on top of the luminaire, please use the models which provide metal flexible conduit instead of bare wire.

- ◆ **Mounting Height:** This product meets or exceeds the NFPA minimum light requirements with all loads, down to the smallest rated lamp load, at heights up to 7.17ft (2.2m). Many factors influence emergency illumination levels, such as the lamp load selected, luminaire design, and environmental factors. Therefore end use verification is necessary. For field installations, when the attached luminaire is mounted at heights greater than 7.17ft (2.2m), the level of illumination must be measured in the end application to ensure the requirements of NFPA 101 and local codes are satisfied.
- ◆ **Remote Mounting:** The emergency LED driver may be remote mounted from the luminaire. If used in conjunction with an AC driver the allowed distance is up to half the distance the AC driver manufacturer recommends remote mounting the AC driver from the LED load. If used without an AC driver, and remote mounting more than 18 feet from the luminaire, please consult the factory to determine the necessary wire gauge. CAUTION: Remote mounting can result in reduced power output.

STEP #2 INSTALLING THE 4-WIRE TEST SWITCH ON FIXTURE SURFACE

- ◆ Mount the supplied 4-wire illuminated test switch in a location that is visible and accessible by maintenance personnel. The switch mounts through a hole which may need to be added to the luminaire or could come pre-punched by the luminaire supplier.
- ◆ Wire the test switch per wiring diagrams provided on these instructions.
- ◆ If wired correctly, the test switch indicator light should be "ON" when AC power is supplied to the fixture, and the battery connector is connected indicating that the emergency inverter battery is charging.

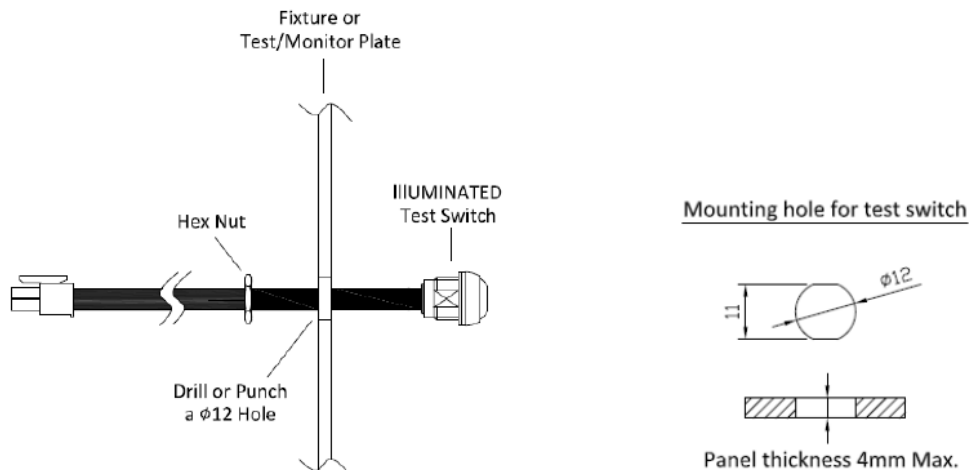

STEP #3 WIRING THE EMERGENCY DRIVER

Select the appropriate wiring diagram to connect the emergency driver to the AC driver and LED load. Make sure all connections are in accordance with the National Electrical Code and any local regulations. After installation is complete, supply AC power to the emergency driver and join battery connector. At this point, power should be connected to both the AC driver and the emergency driver, and the Charging Indicator Light should illuminate indicating the battery is charging.

A short term discharge test may be conducted after the emergency driver has been charged for 1 hour. A full 24 - hour charging period must be performed before conducting a 90 minute discharge. Refer to the OPERATION section of the specs.

"CAUTION - This Unit Has More Than One Power Connection Point. To Reduce The Risk Of Electric Shock, Disconnect Both The Branch Circuit-Breakers Or Fuses And Emergency Power Supplies Before Servicing."

OPERATION

During normal operation AC power is applied to the driver and the charging indicator light is illuminated, which indicates that the battery is being charged. When power fails, the emergency LED driver will automatically switch to emergency power (internal battery), operating the LED load for a minimum of 90 minutes. When AC power is restored, the emergency driver returns to the charging mode.

MAINTENANCE

Although no routine maintenance is required to keep the emergency driver functional, it should be checked periodically to ensure that it is working. The following schedule is recommended:

1. Visually inspect the charging indicator light monthly. It should be illuminated. If the charging Indicator is off, contact tech support.
2. Test the emergency operation of the fixture at 30-day intervals for a minimum of 30 seconds. The LED load should operate at reduced illumination.
3. Conduct a 90-minute discharge test once a year. The LED load should operate at reduced illumination for at least 90 minutes.

! REFER ANY SERVICING INDICATED BY THESE CHECKS TO QUALIFIED PERSONNEL!

T CASE TEST POINT LOCATION

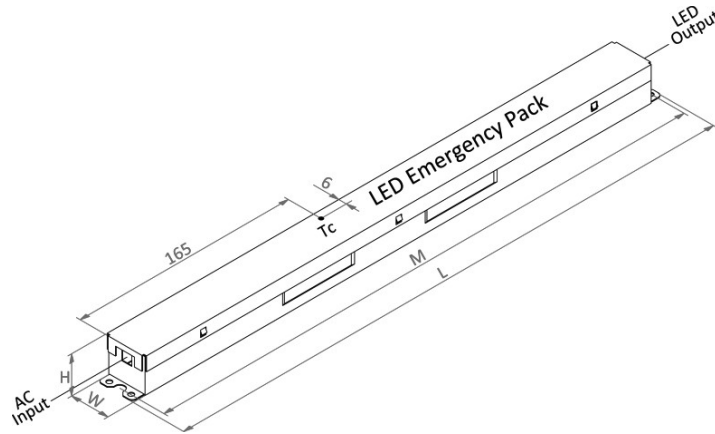
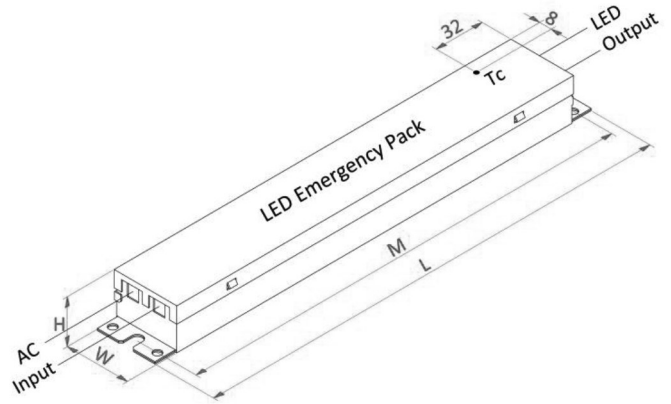
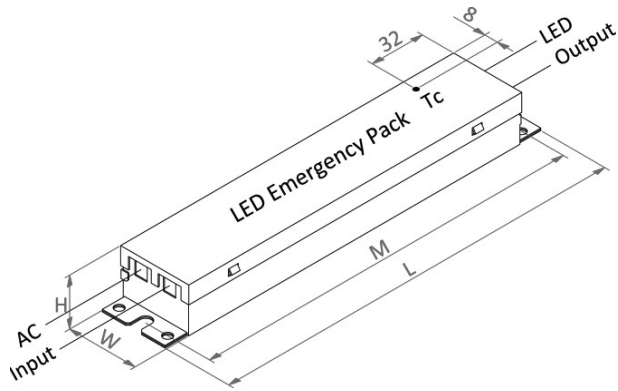

5/10/14 W Emergency LED Driver

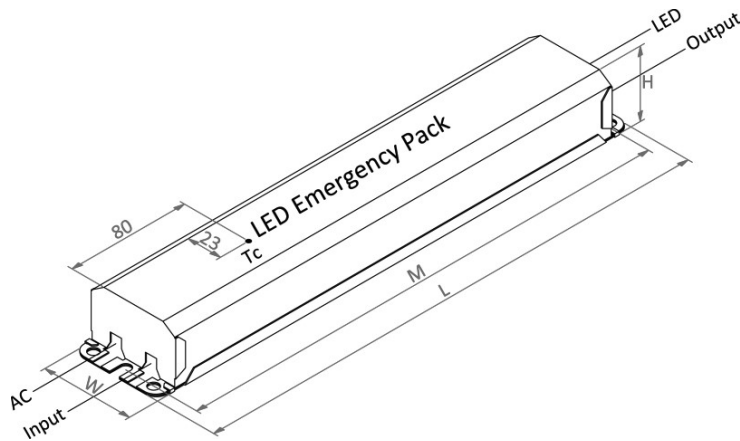

20/25/30W Emergency Driver

EMERGENCY DRIVER AND AC DRIVER MUST BE FED FROM THE SAME BRANCH CIRCUIT TYPICALLY. IT MAY BE USED WITH OTHER AC DRIVERS, CONSULT THE FACTORY FOR OTHER WIRING DIAGRAMS.

SYSTEM WIRING DIAGRAM

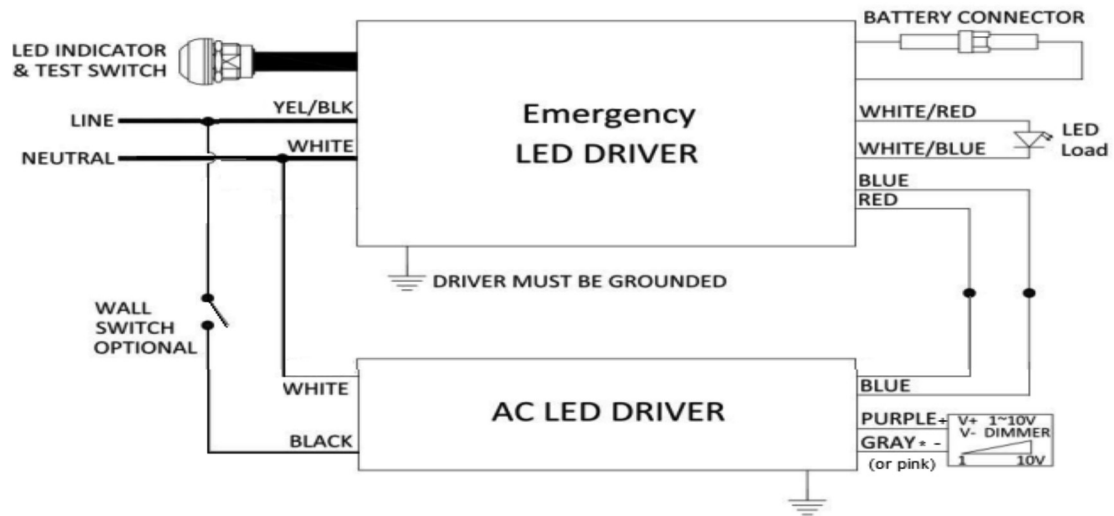

Figure A. Overall Wiring Diagram option 1.

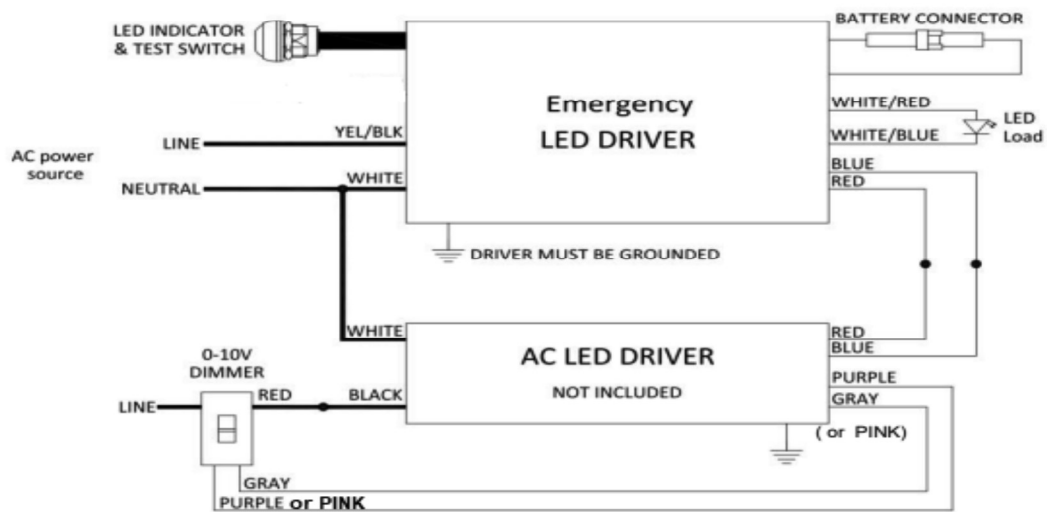

Figure B. Overall Wiring Diagram option 2.

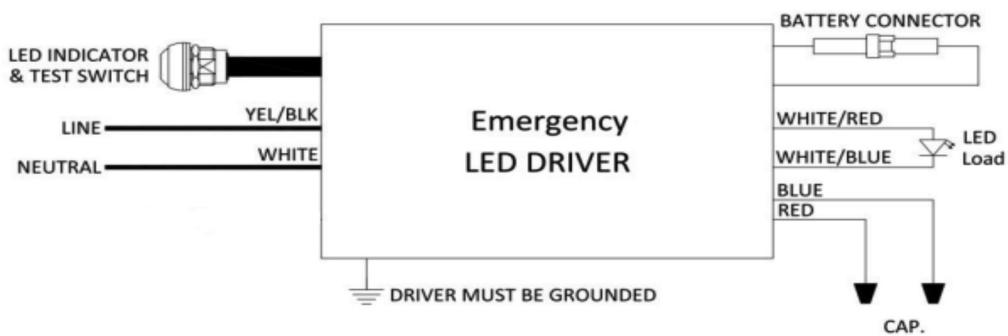

Figure C. EMERGENCY ONLY

SYSTEM WIRING DIAGRAMS

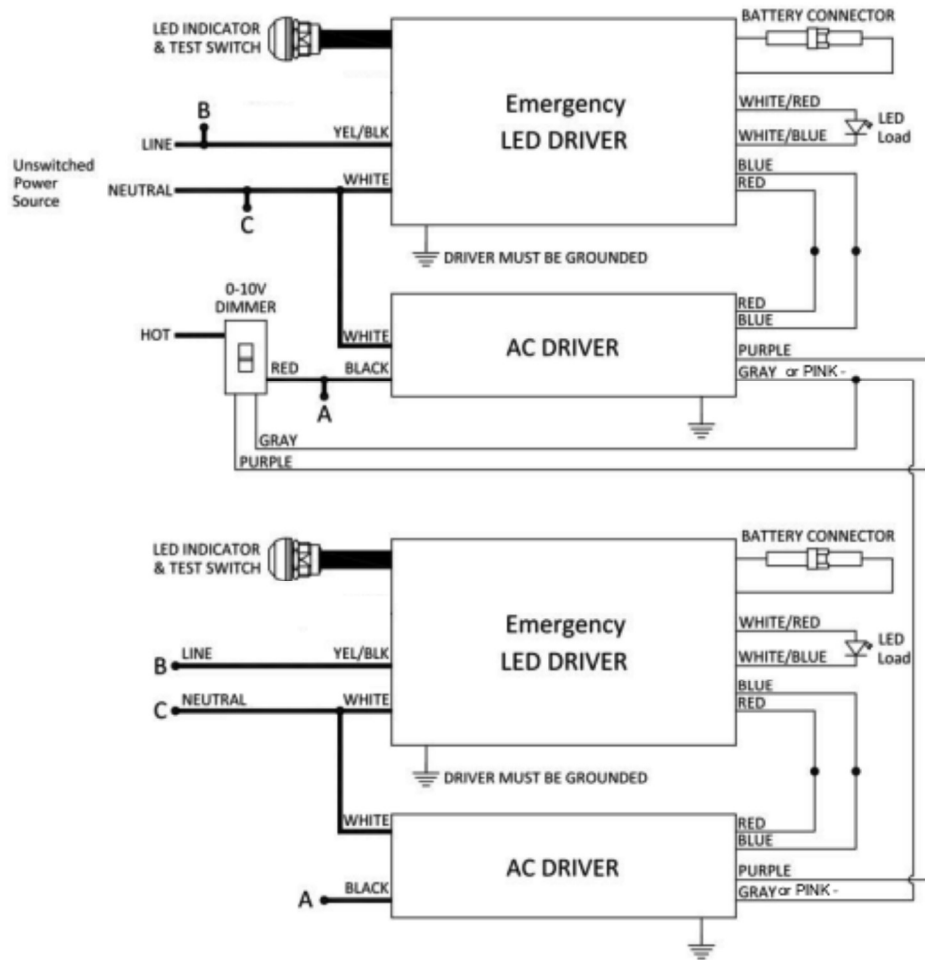
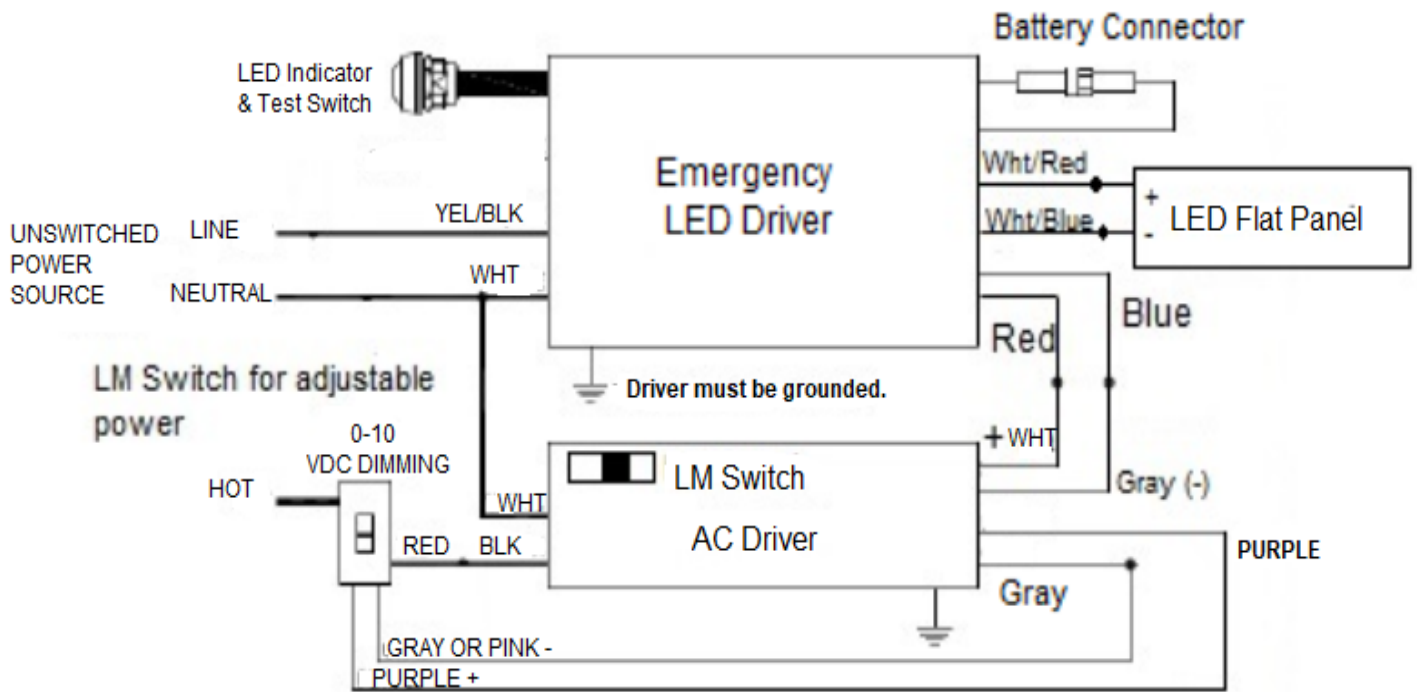

Figure D. Multiple Luminaires with Dimming Drivers

Note: 2022 Codes changing 0-10Vdc Dimming wires from Gray (-) to Pink (-).

SYSTEM WIRING DIAGRAMS



NOTE: Some Flat Panel LED Lighting Luminaires use AC Drivers with White+ and Gray (or Pink) - output wired. The leads from the AC driver to the LED array will need to be cut and wired as shown. Adjustable Lumen diagram shown,

Figure F.

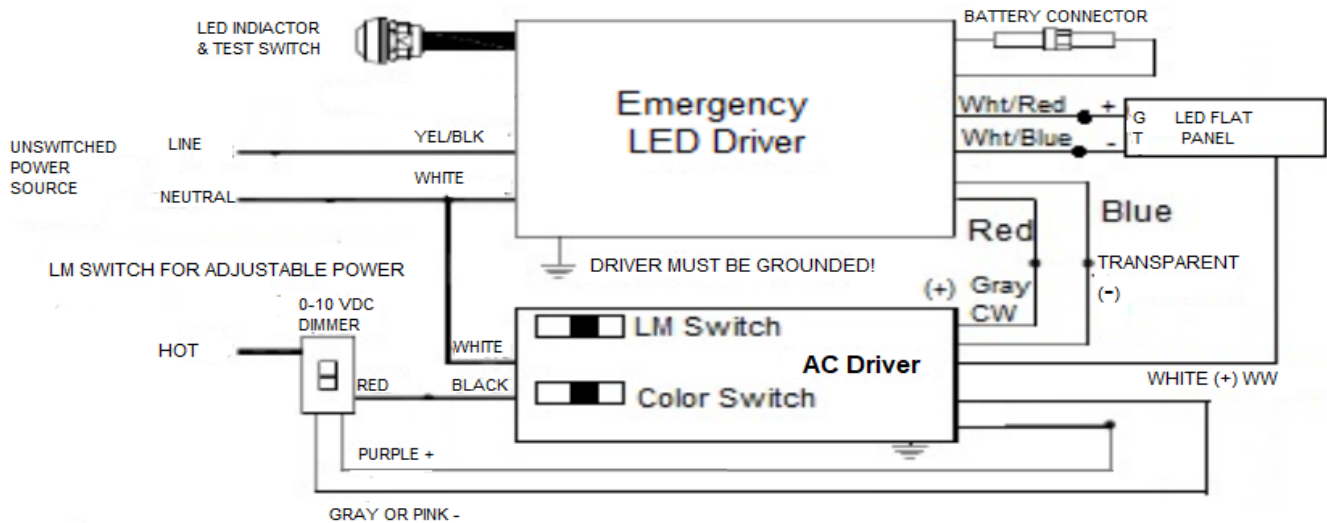

NOTE: Some adjustable Lumen & Color Flat Panel luminaires use AC drivers with Gray CW(+), and Transparent (-) and White WW output wires. The proper leads from the AC driver will need to be cut and wired as shown. White output wire is not cut. Adjustable Lumens and Color system diagram shown.

Figure G.

Note: 2022 Codes changing 0-10Vdc Dimming wires from Gray (-) to Pink (-).